

R314LV-30 Series is a vertically mounted Modular DAS Tray solution that can hold up to 8 Attenuator Modules on a 4RU High Rack or H-Frame. Each Attenuator Module (Model #: 314LV-30-D43-QMA) has 4x 30dB attenuators integrated in one housing, each having its own independent RF path. Each attenuator path can handle 50W of power and operates from 600MHz - 4200MHz. These attenuators are guaranteed for Low-PIM performance in the entire frequency range. They come with 4.3-10(F) Connector on the Input side and QMA(F) connector on the Output side.

This DAS Tray Solution is a complete **Passive System** and requires no additional Interface Card or AC power for this to operate. Each DAS Solution includes the following:

- **4RU Sub-Rack (PN: R314LV-4RU)** – Holds up to 8 Attenuator Modules
- **Attenuator Module (PN: 314LV-30-D43-QMA)**
(Each Module has 4x 30dB Attenuator, each having an independent RF path)

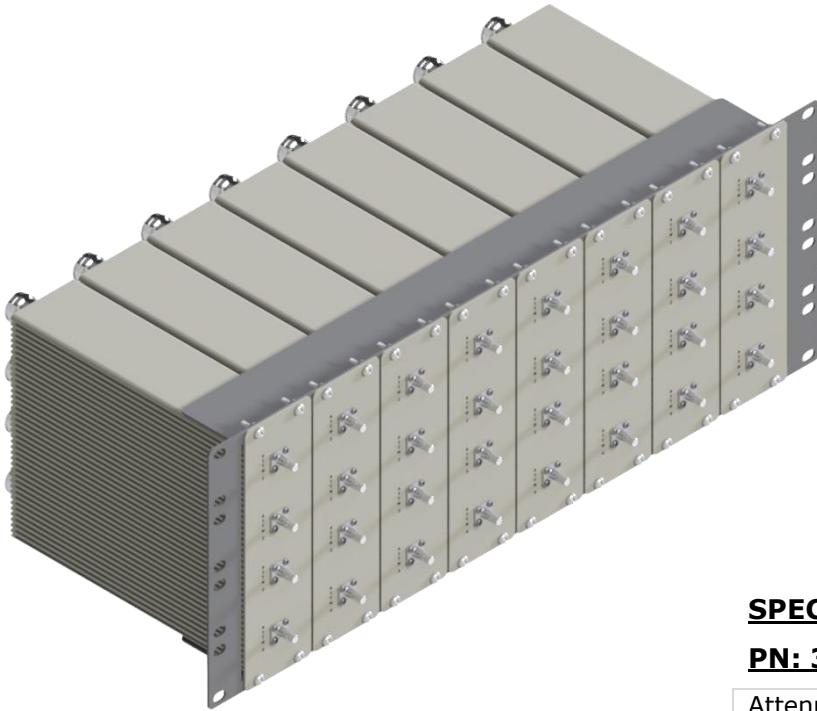

- Up to 8 Attenuator Modules
- Each Module has 4x 30dB Attn with each having an independent RF Path.
- INPUT - 4.3-10 (F)
OUTPUT – QMA (F)
- **CBRS / C-Band** Ready
- Low PIM , -161dBc
- In Stock to low lead time delivery

SPECIFICATIONS for 4RU Sub-Rack

PN: R314LV-4RU:

Attenuator Modules	8 (max)
Rack Space Needed	4 RU
Temperature Range	-30°C to 70°C
Weight	3.50 lbs
Dimensions	6.97”(H) x 19.00”(W) x 2.00”(D)

SPECIFICATIONS for ATTN MODULE

PN: 314LV-30-D43-QMA:

Attenuation	30dB
Attenuation Accuracy	±1.25
No. of Attenuators	4 (Independent RF Path)
Frequency Range	600MHz - 4200MHz
Return Loss	20 dB (Typ)
Intermodulation (PIM - 3 rd)	-161 dBc (Typ) (2 Tones +43 dBm)
Impedance	50 Ohms
Input Power	50W (Average Power)
Temperature Range	-30°C to 70°C
Connector	IN - 4.3-10(F) / OUT – QMA(F)
Weight	7.50 lbs
Dimensions (in)	6.97”(H) x 2.05”(W) x 7.31”(D)

Dimensions for Attenuator Module (PN: 314LV-30-D43-QMA)

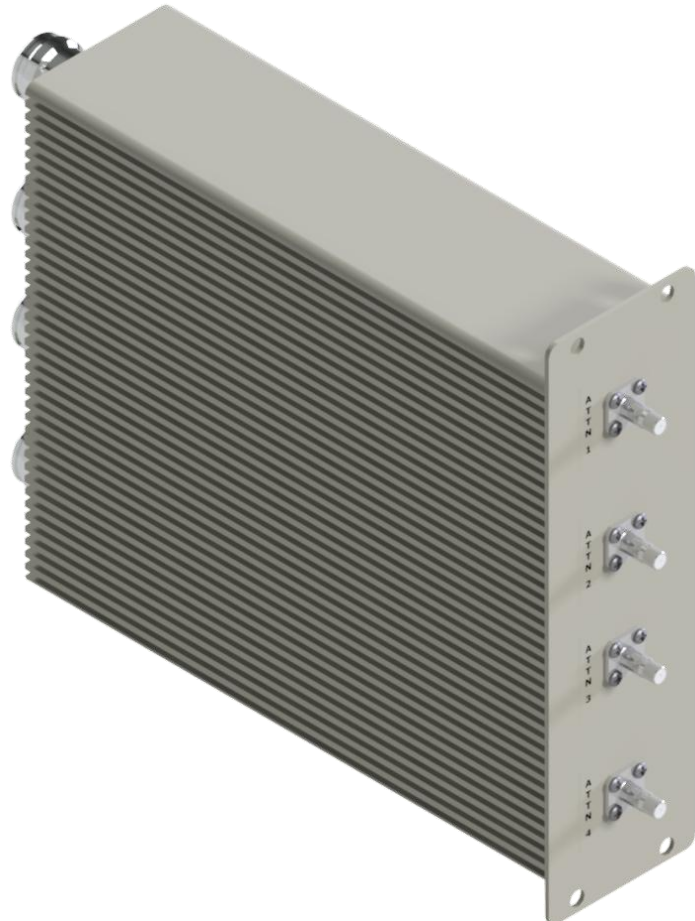
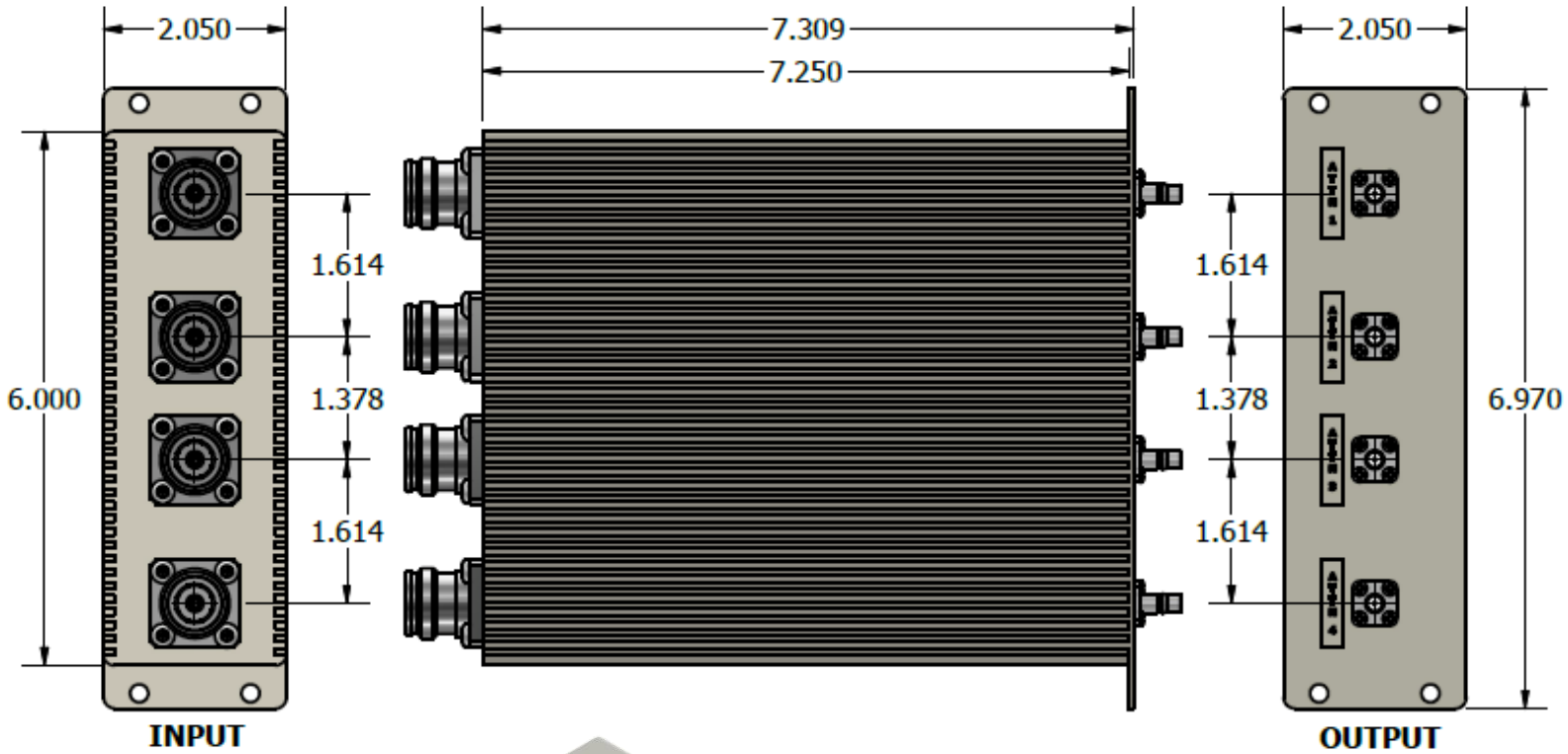

Dimensions for 4RU Sub-Rack (PN: R314LV-4RU)

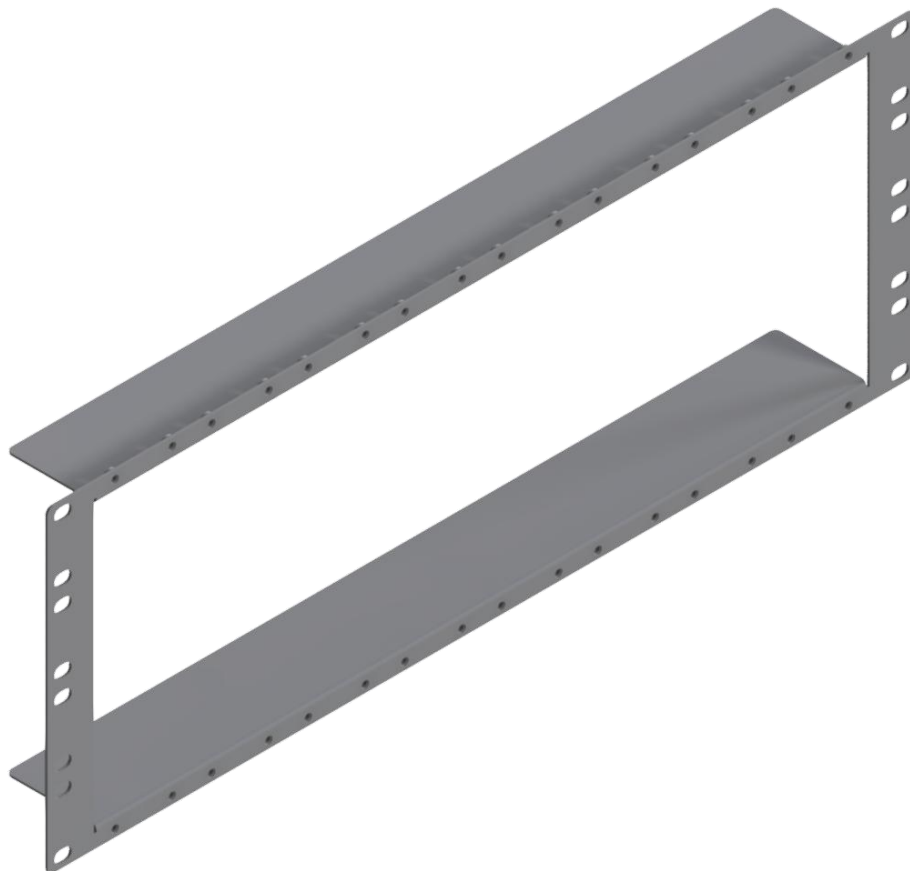
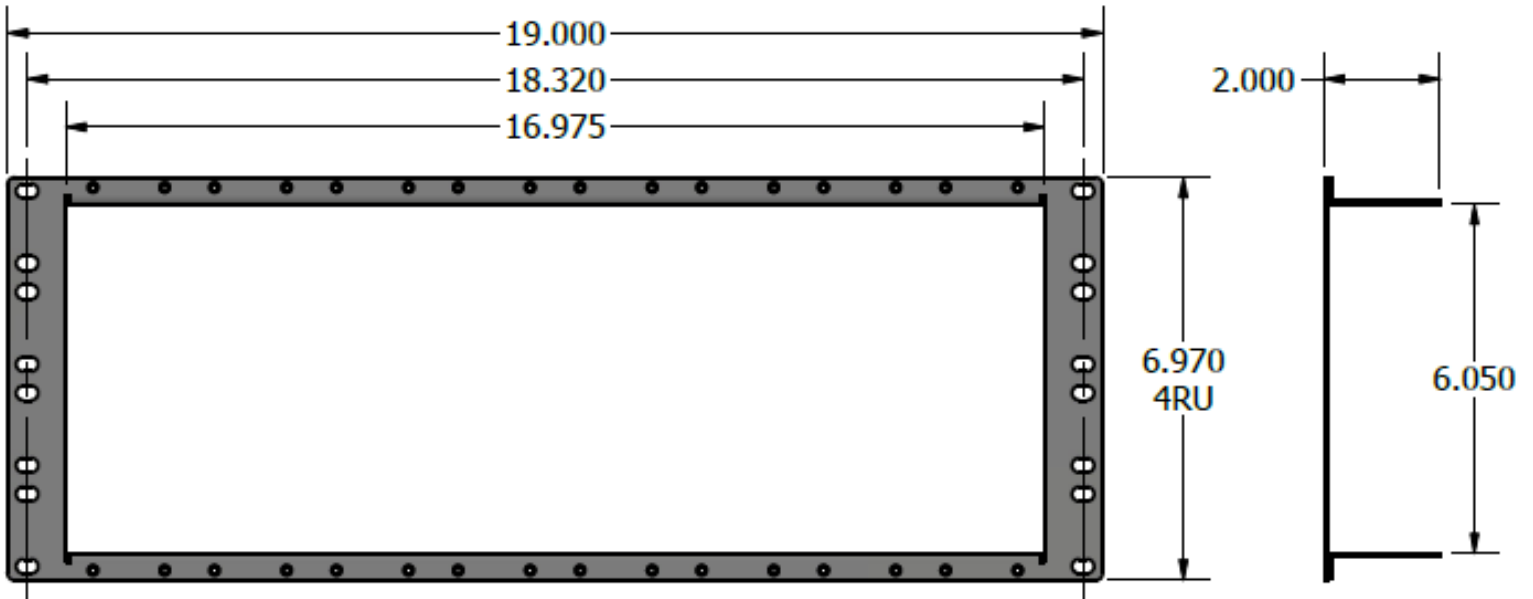

R314LV-4RU Assembly with 8 Attenuators

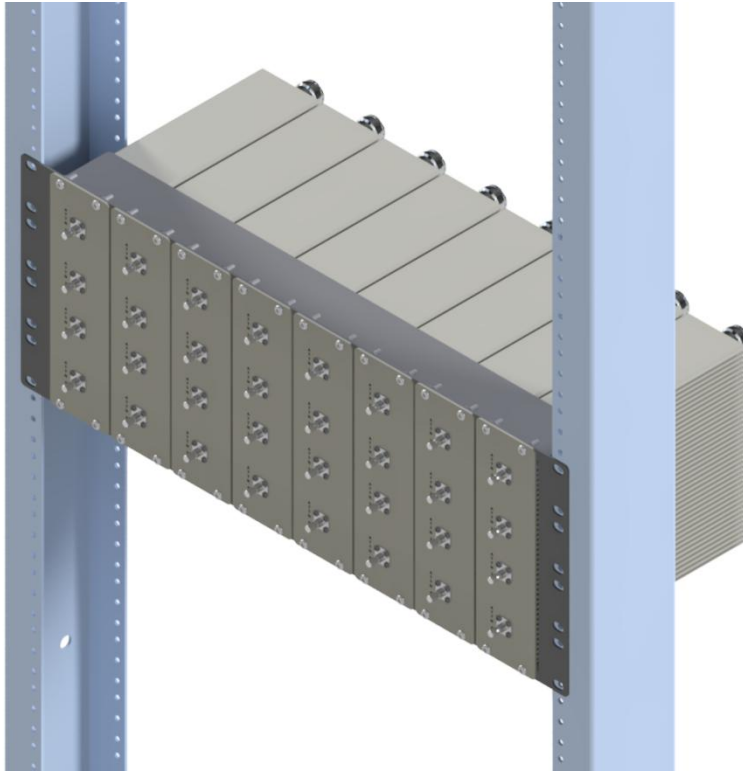

R314LV-4RU Assembly with 5 Attenuators

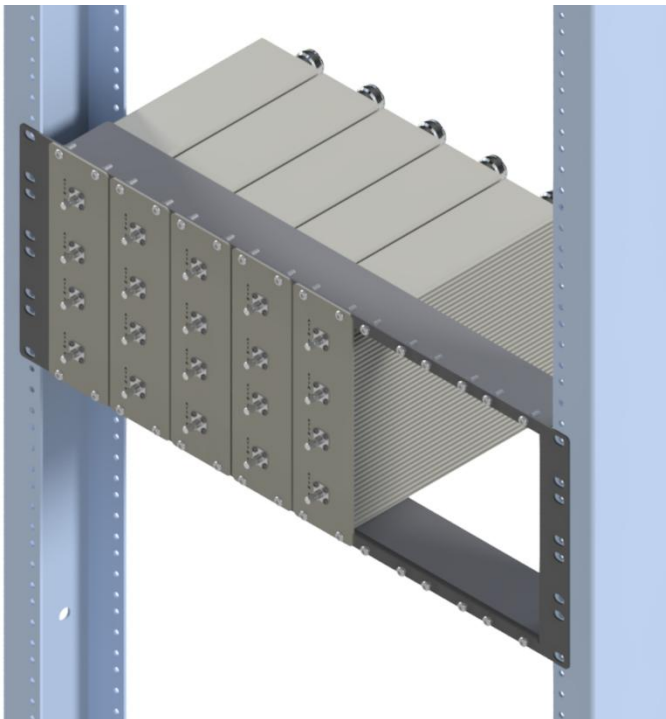

Please contact our sales department at 737-200-7090 or sales@InnowaveRF.com for any custom requirements.

© Innowave RF, LLC. All Rights Reserved. Specs can change without notice. Drawings are for reference purpose only.